



**FASTER**



**GREENER**



**SMARTER**



**RELIABLE**

**MPH150**



**SACMI**

Powder Metal Solutions

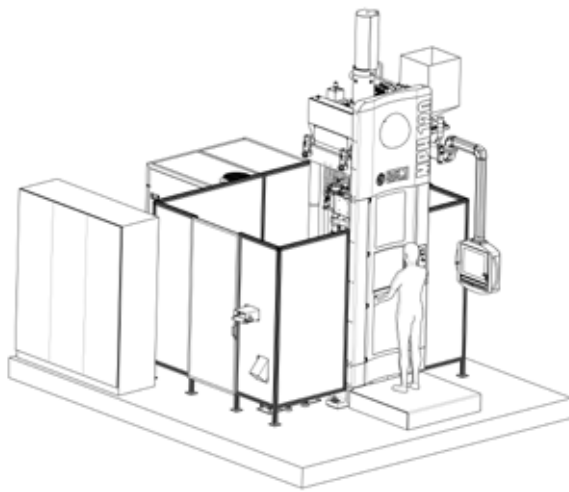
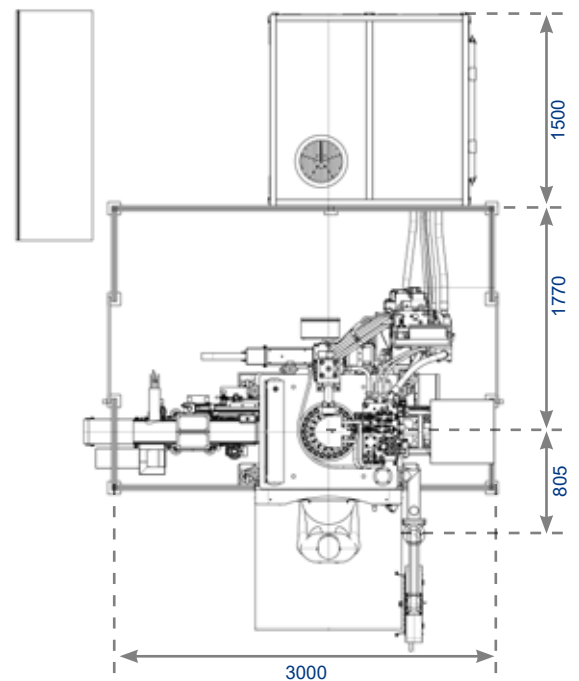
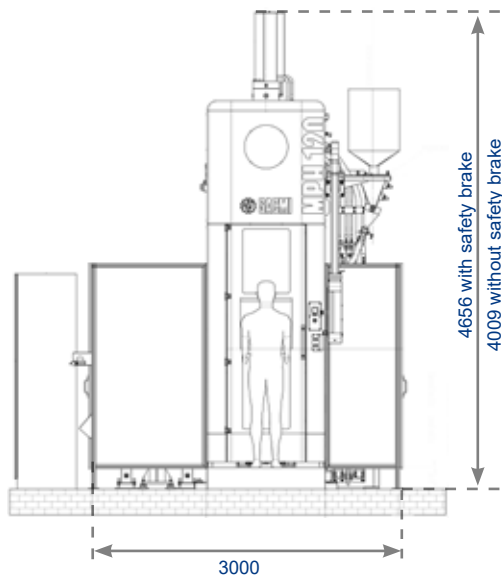

# MPH150

**FULLY AUTOMATIC CNC PROGRAMMABLE  
HYDRAULIC PRESS FOR  
POWDER METAL COMPACTION  
PRESSA IDRAULICA AUTOMATICA  
PER POLVERI METALLICHE  
CNC-GEREGLTE HYDRAULISCHE  
PULVERPRESSE**

## TECHNICAL DATA - DATI TECNICI - TECHNISCHE DATEN

|   |    |        |   |    |     |
|---|----|--------|---|----|-----|
| Max pressing force<br>Massima forza di compattazione<br>Max. Presskraft   | kN | 1,500  | Die-set lower levels stroke (Y1 - Y2 - Y3)<br>Corsa punzoni inferiori (Y1 - Y2 - Y3)<br>Hub unteren Zusatzachsen (Y1 - Y2 - Y3) | mm | 60  |
| Hydraulic oil volume<br>Volume di olio idraulico<br>Ölmenge   | l  | 800    | Die-set core rod stroke (Z1)<br>Corsa spina (Z1)<br>Hub Mittelstift (Z1)  | mm | 120 |
| Installed power up to<br>Potenza installata fino a<br>Installierte Gesamtleistung bis zu                                      | kW | 96     | Die-set maximum filling height (Z)<br>Massima altezza di caricamento (Z)<br>Max. Füllhöhe (Z)                                   | mm | 120 |
| Total weight (with die-set)<br>Peso totale (con adattatore)<br>Gesamtgewicht (inkl. Adaptor)                                  | Kg | 11,000 | Maximum die counterforce (Z)<br>Massima controforza tavola porta matrice<br>Max. Gegenhaltekräft (Z)                            | kN | 610 |
| Die-set upper levels stroke (X1 - X2 - X3)<br>Corsa punzoni superiori (X1 - X2 - X3)<br>Hub obere Zusatzachsen (X1 - X2 - X3) | mm | 40     | Maximum die ejection force (Z)<br>Massima forza di estrazione (Z)<br>Max. Abzugskraft (Z)                                       | kN | 350 |



SACMI IMOLA S.C.  
Via Selice Prov.le, 17/A - 40026 Imola Bo - ITALY  
Tel. +39 0542 607111 - powdermetal@sacmi.it  
www.sacmi.com

